

SINCE 1944

\* Specifications in this catalog are subject to change without prior notice.  
\* Please contact us or visit our site for more product information.

# DL G series

## Gang Type Flat Bed CNC Turning Center (En)

DL 3G / 5GH / 6GF  
Q5-2S

[www.ffg-dmc.com](http://www.ffg-dmc.com)



**FFG DMC CO.,LTD.**

631-821,86,Sandan 2-gil, Jinbuk-myeon, Masanhappo-gu,  
Changwon-si, Gyeongsangnam-do, Korea

Phone : +82-(0)55-340-8200

Fax : +82-(0)55-340-8394

E-mail : [sales@dmcmt.com](mailto:sales@dmcmt.com)

[www.ffg-dmc.com](http://www.ffg-dmc.com)



© FFG DMC 2017.11.09



# DL G series Flat Bed

DL 3G

DL 5GH

DL 6GF

Q5-2S



Flat Bed Turning Center, Dove Tail Slide(X,Z) is optimal in small parts processing(3"~6")

**Why?** Why should a customer select FFG DMC DL G series for small-size workpiece?

**Speed**

To produce small-sized workpiece, it has to be high precision and needs to reduce tool change time, compact floor installation. DL G series\_Flat Bed composed of flat bed, Dove tail slide and Gang type is the best choice for small sized-workpiece

**Accuracy**

Turret type optimizes repeated precision while rotating. Flat Bed type can minimize the change by horizontal movement and Gang type's tool post doesn't affect repeatability, positioning or precision. That's why DL G series\_Flat Bed is best in precision processing under 10um.

**High productivity**

Processing small size-workpiece should be strong for the vibration due to short distance between Tool and spindle center on the slide surface. So it needs Flat Gang type applying Dove tail slide to X/Z axis. if you choose FFG DMC's DL G series\_Flat Bed, you can increase minimum 10% productivity.



**DL 3G**

Travel (X/Z) (mm)(inch)	200 × 180 (7.87"x7.09")
Guideway Type	Dove-tail
Spindle speed (rpm)	6,000
Number of tools (pcs)	5



**DL 6GF**

Travel (X/Z) (mm)(inch)	200 × 200 (7.87"x7.87")
Guideway Type	Dove-tail
Spindle speed (rpm)	6,000
Number of tools (pcs)	3



**DL 5GH**

Travel (X/Z) (mm)(inch)	300 × 235 (11.81"x9.25")
Guideway Type	Dove-tail
Spindle speed (rpm)	6,000
Number of tools (pcs)	5



**Q5-2S**

Travel (X/Z) (mm)(inch)	300 × 235 (11.81"x9.25")
Guideway Type	Dove-tail
Spindle speed (rpm)	6,000
Number of tools (pcs)	5

By applying Twin spindle, Work efficiency increased.

## High Productivity

### Spindle

DL 3G

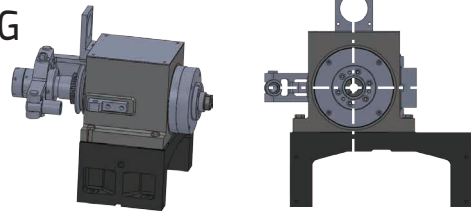

DL 5GH

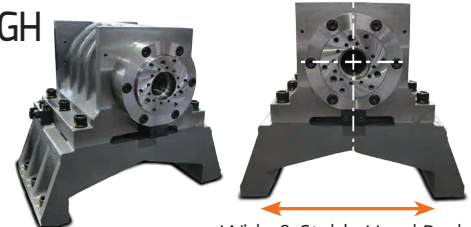

Wide & Stable Head Body



## Increase productivity with high speed, high accuracy spindle

As one bed structure of bilateral symmetry has been designed to minimize heat strain & spindle acceleration and deceleration, it can facilitate the high precision cutting during high speed processing. furthermore customer can increase the productivity.

Max. spindle speed **6,000rpm**

Max. spindle motor (DL 6GF) **7.5/11kw**

**10/14.7hp**



( ) : Option

	DL 3G	DL 5GH	DL 6GF	Q5-2S
Chuck Size	inch 3/Collet	5	6	5
Spindle Bore dia.	mm[inch] 32[1.26]	44[1.73]	55[2.17]	26[1.02]
Spindle Speed	rpm 6,000	6,000	6,000	6,000
Main Spindle Motor	kw[hp] 3.7/5.5[5/7.4]	3.7/5.5[5/7.4]	7.5/11[10/14.7]	<2.2x3.7>x2[<3/5>x2]
Spindle Torque	kgf-m[lbs-ft] 3.5[25]	3.5[25]	3.65[26]	2.4[17]
Spindle Driven Method	Belt	Belt	Belt	Built-in
Spindle Nose	FLAT	FLAT	A2-5	A2-4

DL 6GF

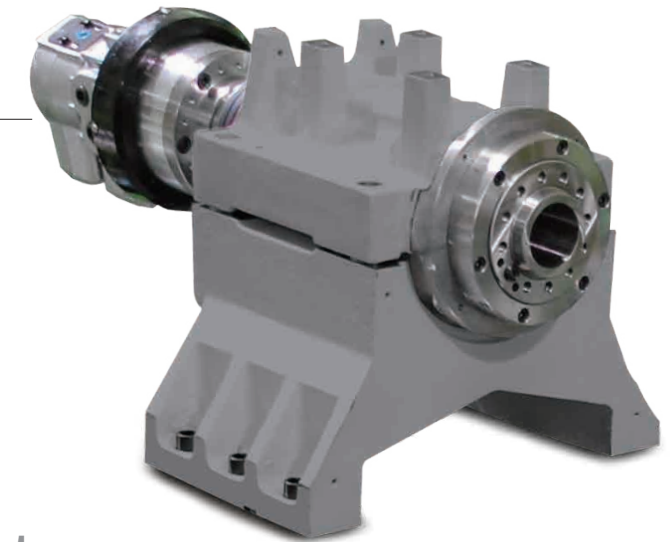
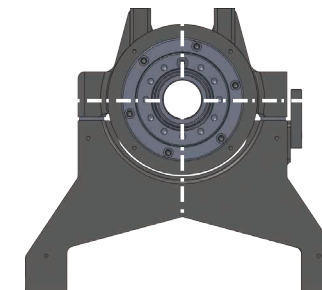

## Stable spindle structure

- Because of separation between Spindle Cartridge and Head Body, it can block the transfer of heat.
- Cooling effect as designed Air Circulation Tunnel(Aerial exposure in the bottom of structure)
- When repairing, only Cartridge needs to be changed.
- Keep Accuracy with blocking vibration and heat strain

## Power & Torque Diagram

DL 3G, DL 5GH

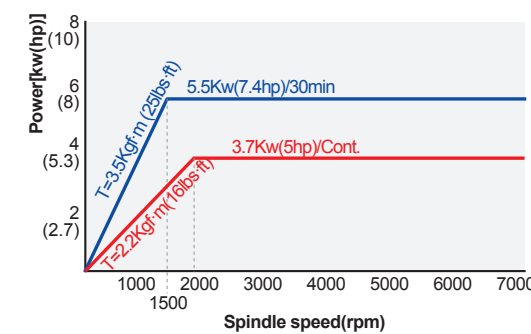

DL 6GF

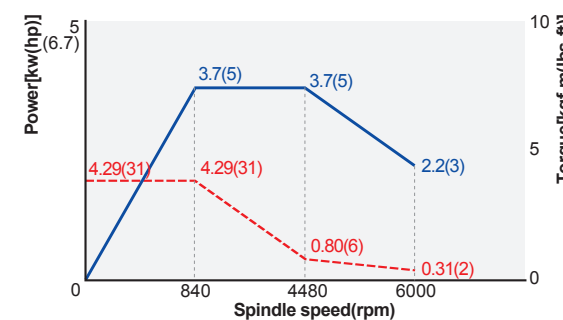
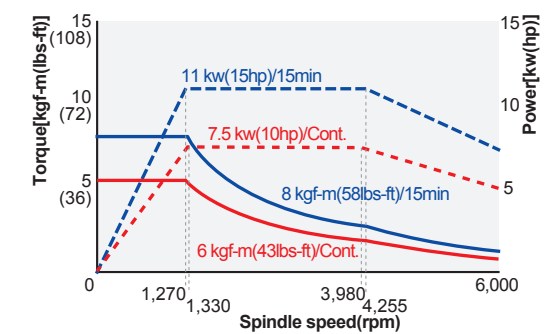

Q5-2S (Built-in Spindle)



## High Productivity

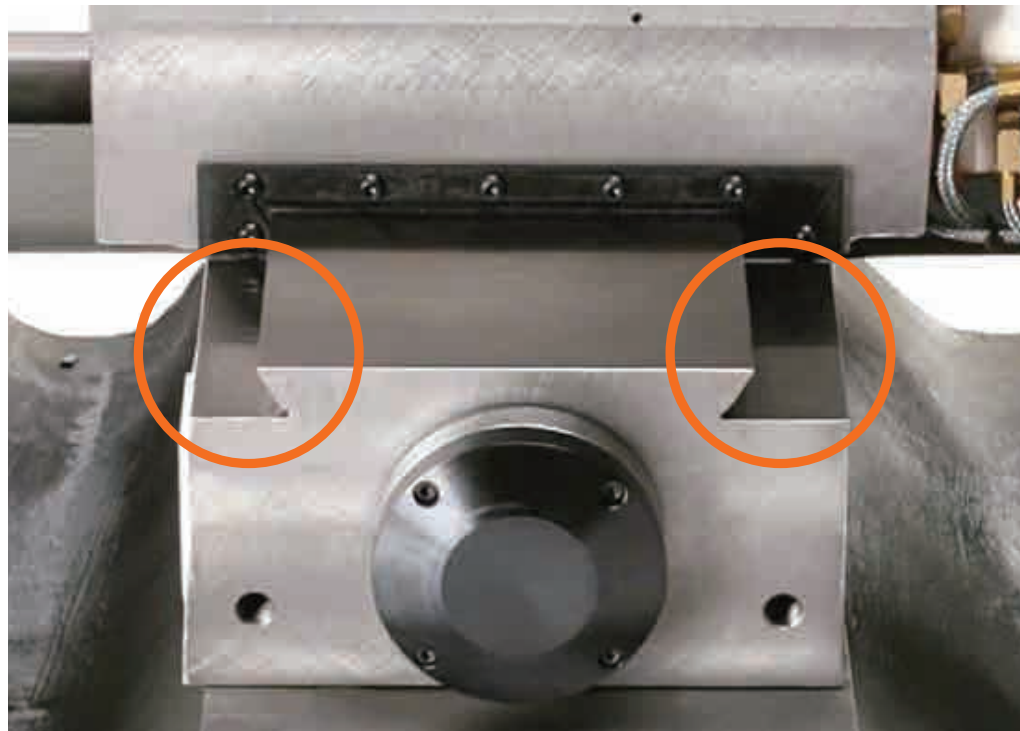

### Dove tail Slide

low position, high rigidity, high precision and compact design.

- ▶ minimal change for repeated measurement in short moving distance

- By applying Dove tail slide which is strong structure without vibration during interrupted cutting, it can be high power cutting, also guarantee the stable machined surface than LM guide.
- Flat Bed type assures excellent precision in comparison with Slant Bed

	Travel(X/Z)	Rapid traverse rate(X/Z)
DL 3G	200/180mm(7.87/7.09inch)	15/15m/min(590.55/590.55ipm)
DL 5GH	300/235mm(11.81/9.25inch)	24/24m/min(944.88/944.88ipm)
DL 6GF	200/200mm(7.87/7.87inch)	24/24m/min(944.88/944.88ipm)
Q5-25	300/235mm(11.81/9.25inch)	24/24m/min(944.88/944.88ipm)

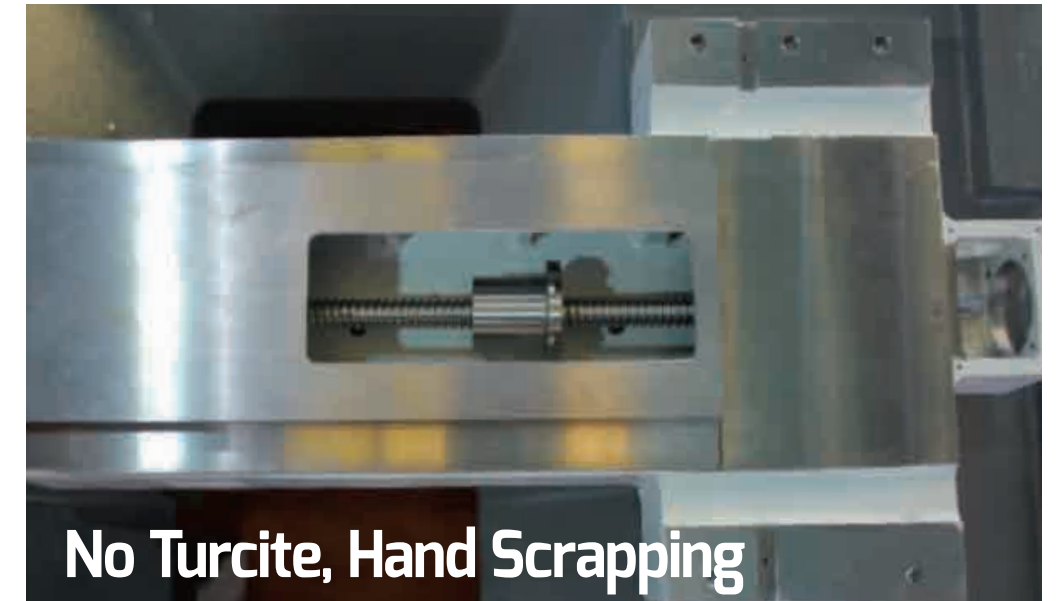
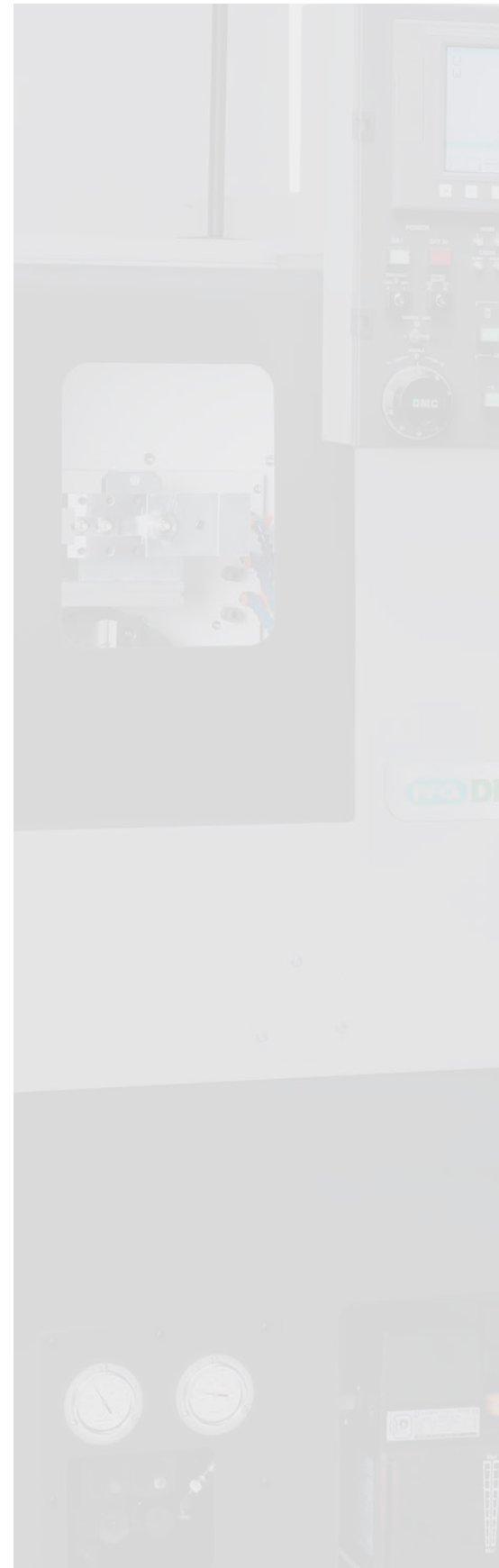

### Cartridge Unit

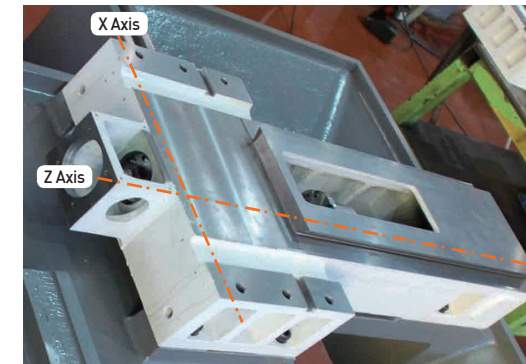

- By Cartridge unit,
  - + easy maintainability, Accurate assembly by scrapping between cartridge bed, Saddle, and Cross unit.
  - + Z-axis is attached inside Cartridge
- By applying wide slide in Dove tail type, it is effect implementation same as box way type.
- No Turcite, Hand Scrapping

### Smooth evaluation for Coolant & Chip

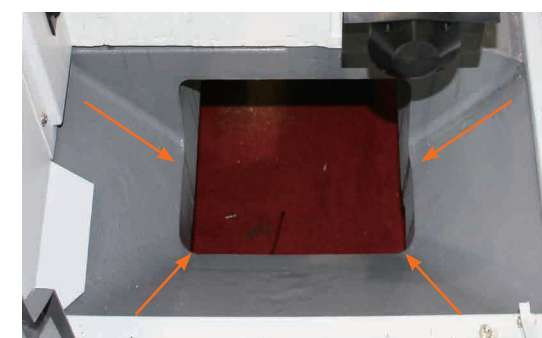

DL 3G, DL 5GH, Q5-25

- + Designed for excellent chip evacuation.

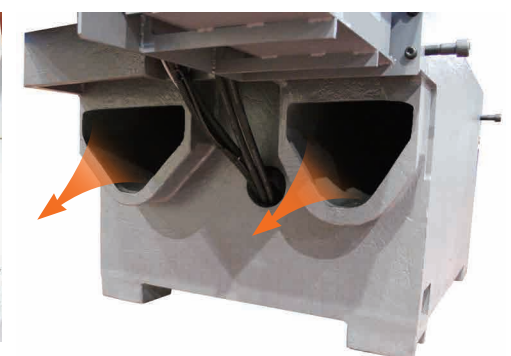

DL 6GF

- + Dual chip evacuation.

## High Productivity

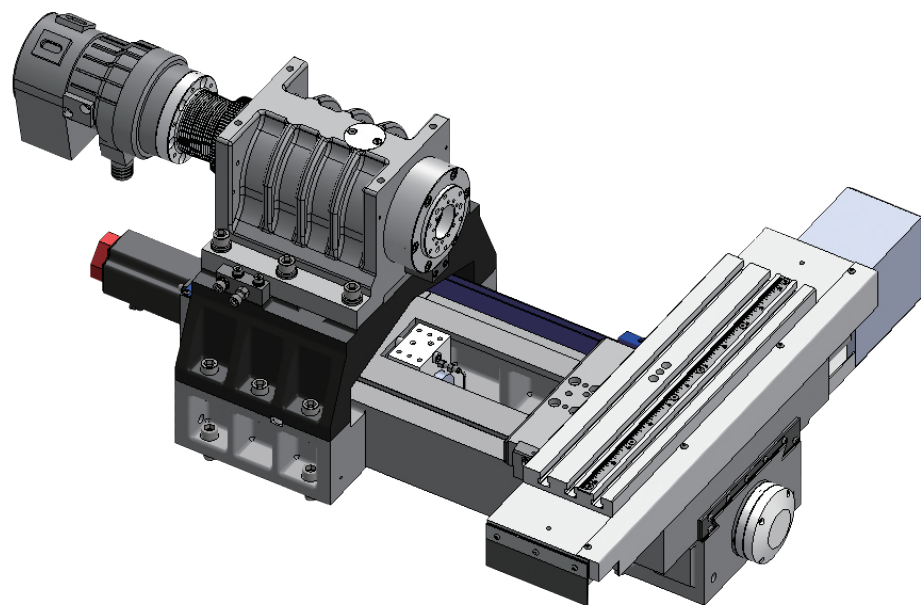

## Easy tool setting

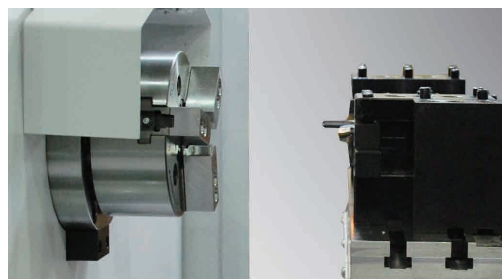

Minimized tool setting time & easy installation.

- T-slot is attached on the top of Flat Table
- Apply coolant nozzle to each tool

## Optimum SPACE

Smaller footprint than competing machines.

( ) : inch

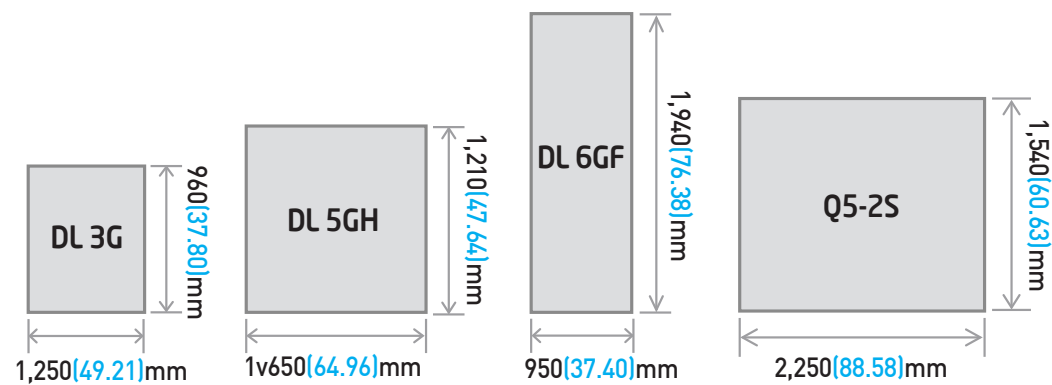

## Accuracy

### BED

The "flat" one piece cast bed ensures high accuracy by minimizing the heat distortion. Design by sturdy casting prevents vibration & distortion and aids chip removal easily.

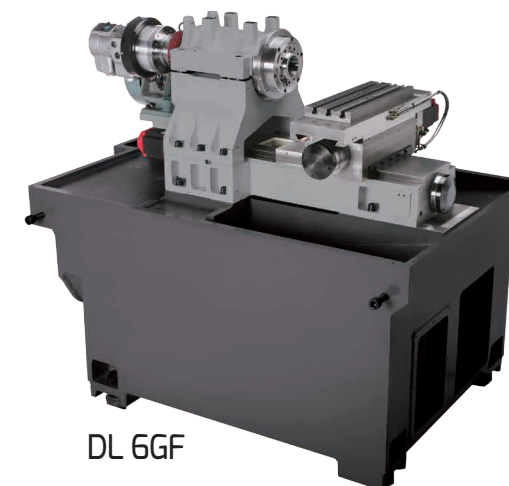

### Ball Screw

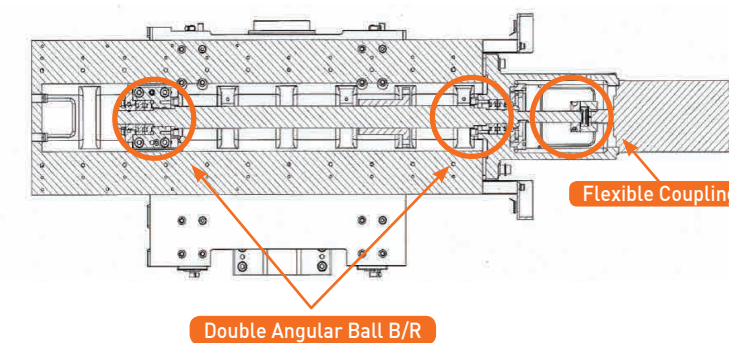

Pre-tension, double-anchored ball screwing ensures precision movement of the machine.

### Roundness

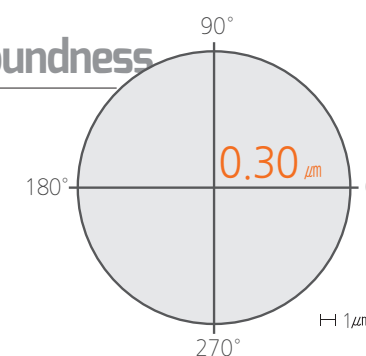

### Surface Profile(OD cutting)

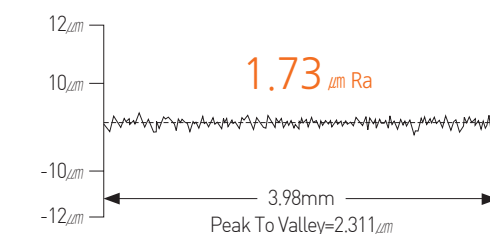

Tool	Diamond tool(nose radius 0.1mm)
Material	AL 150(Aluminum)
Cutting speed	227.3m/min(8949ipm)
Feedrate	0.05mm/rev(0.002ipr)
Depth of cut	0.1 mm
Out diameter	201mm(7.91")

Tool	Diamond tool(nose radius 0.1mm)
Material	AL 150(Aluminum)
Cutting speed	227.3m/min(8949ipm)
Feedrate	0.05mm/rev(0.002ipr)
Depth of cut	0.1 mm
Out diameter	201mm(7.91")

● This is actual cutting result. It might be not available under certain circumstances.



## User-Friendly, Designed for Operator Efficiency / Ergonomics

### 2-Panel Safety Glass

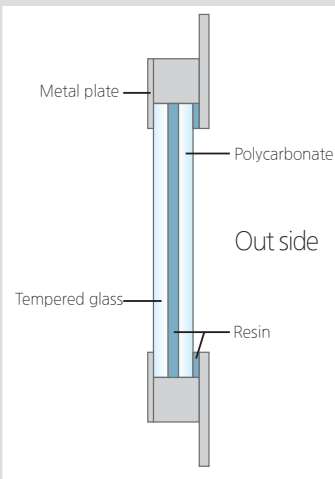

### LED Working Light



+ Long-life LED lighting creates well-lighted work environments.

### Chuck opening checking device.(STD.)

+ Prevent malfunction with chuck opening and close checking device.

### Oil Recovery Box



### Rear Leak Prevention

+ Cover improves work environment.  
+ Wiper protection.

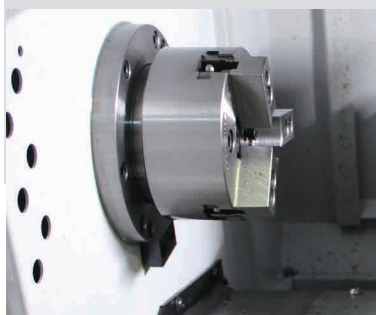

### Coolant Tank 3-Triple Filter for easy cleaning and prevents coolant overflow

+ Installed chip conveyor.

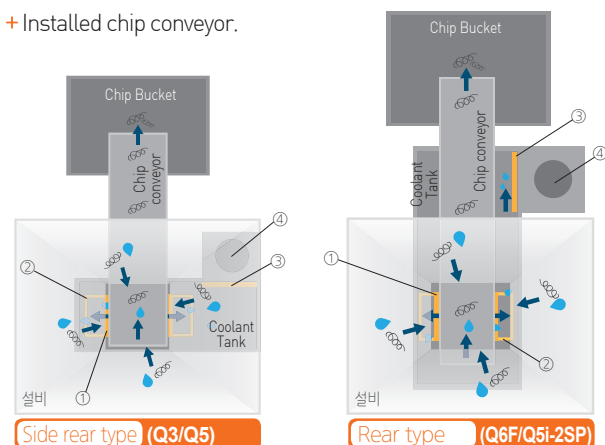

### Spindle load meter is standard

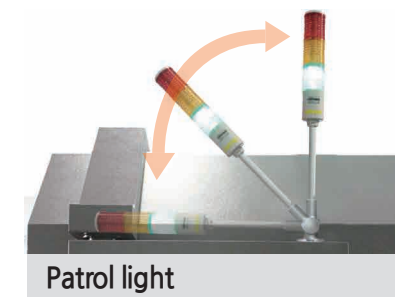

Patrol light

+ LED 3-color lighting can be attached before shipping.

### Front Door Interlock Device



+ CE standard safety switch can sense door opening and close; door is closed during processing.

### RS232C (Input/output interface)



+ USB port

### Easy tool setting

+ Fast and easy tool setting you can identify trouble source easily

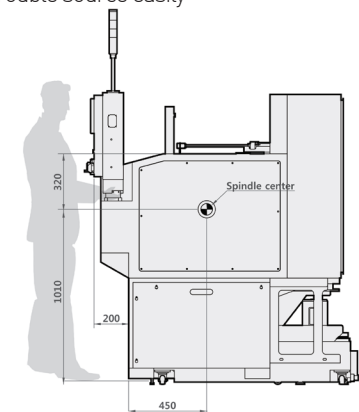

### Removable Coolant Tank



+ Front wheels attached to the structure for ease of cleaning the coolant tank.

Coolant Tank Capacity	50ℓ : DL 3G
	70ℓ : DL 5GH
	110ℓ : DL 6GF
	120ℓ : Q5-2S
Hydraulic Tank Capacity	11ℓ : DL G series_Flat Bed All Model

### Option

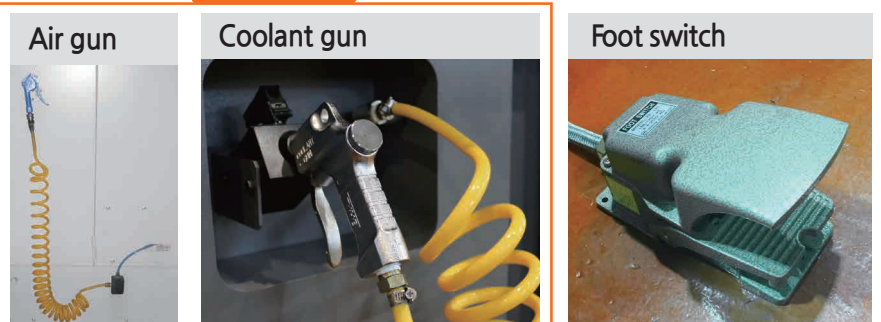

## Automation Examples

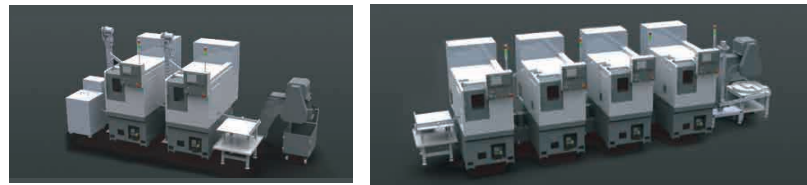

- Model : DL 6GF
- Work piece : Socket
- Cycle time : 16sec/pcs

### Compact space, high productivity.

Front spindle type reduces the floor space(4 units in standard, 27m<sup>2</sup> → 10m<sup>2</sup>), helps reduce worker's, tool setting time and maximize chip processing ability.

### Customize automation line composition.

Based on accumulated, We can provide the optimum automation solution for customer's demand with loading/unloading, variety of chucking system, elevator, hopper, parts conveyor, turn over devices.



## Robot Automation

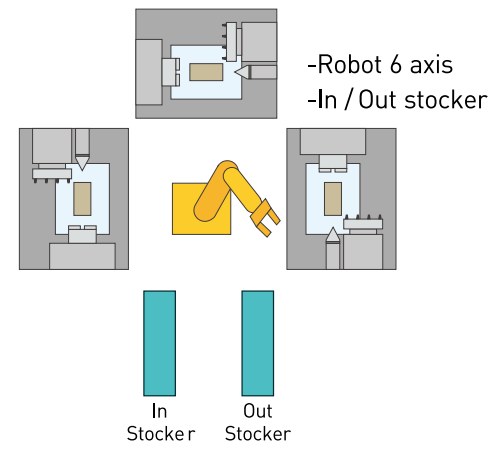

- Model : Q5-2S
- 6 axis automation
- load capacity 3kg

## Gantry Loader Automation

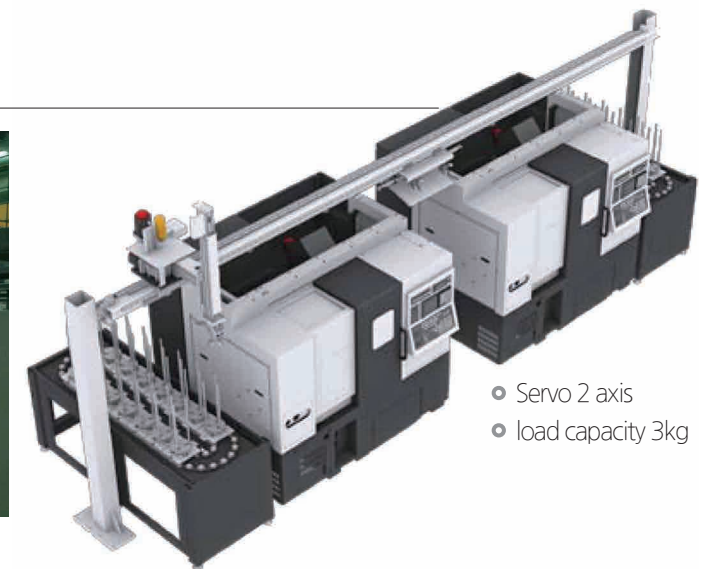

## Front load Automation



- Model : DL 5GH
- Work piece : Valve (Al)
- Loader :  
Air CYL type / Servo motor type
- Cycle time : 18sec/pcs

## Bar Feeder Automation

When using barfeeder, part catcher and out conveyor simultaneously, Maximize the efficiency for processing.

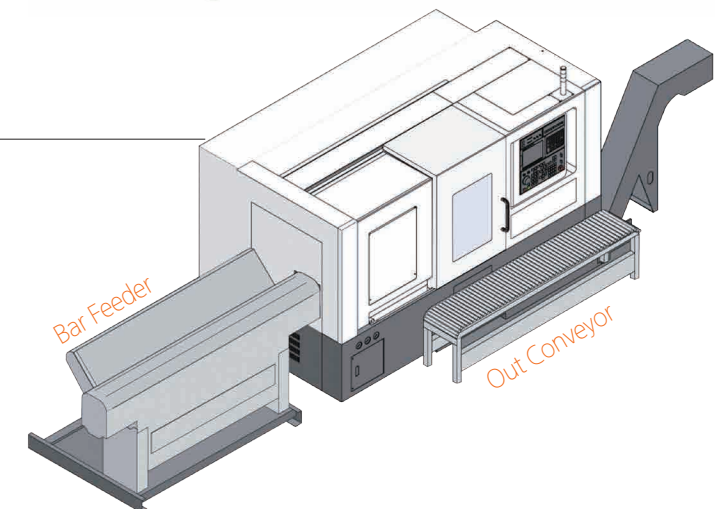



## Options

### Standard Parts

Hydraulic chuck with one set of soft jaws, toolbox with basic tools, hydraulic unit, door interlocks, work light, leveling bolts and plates, foot switch pedal, lubrication system, 3-color alarm lamp, chuck open / close confirmation, RS232C + USB port.

### Options

### Various Soft Options

□ I/O expansion (16-contact, 32-contact)   □ Power disconnection device   ○ M - code

## Tooling Diagram

□ : Option (Not-Supplied)

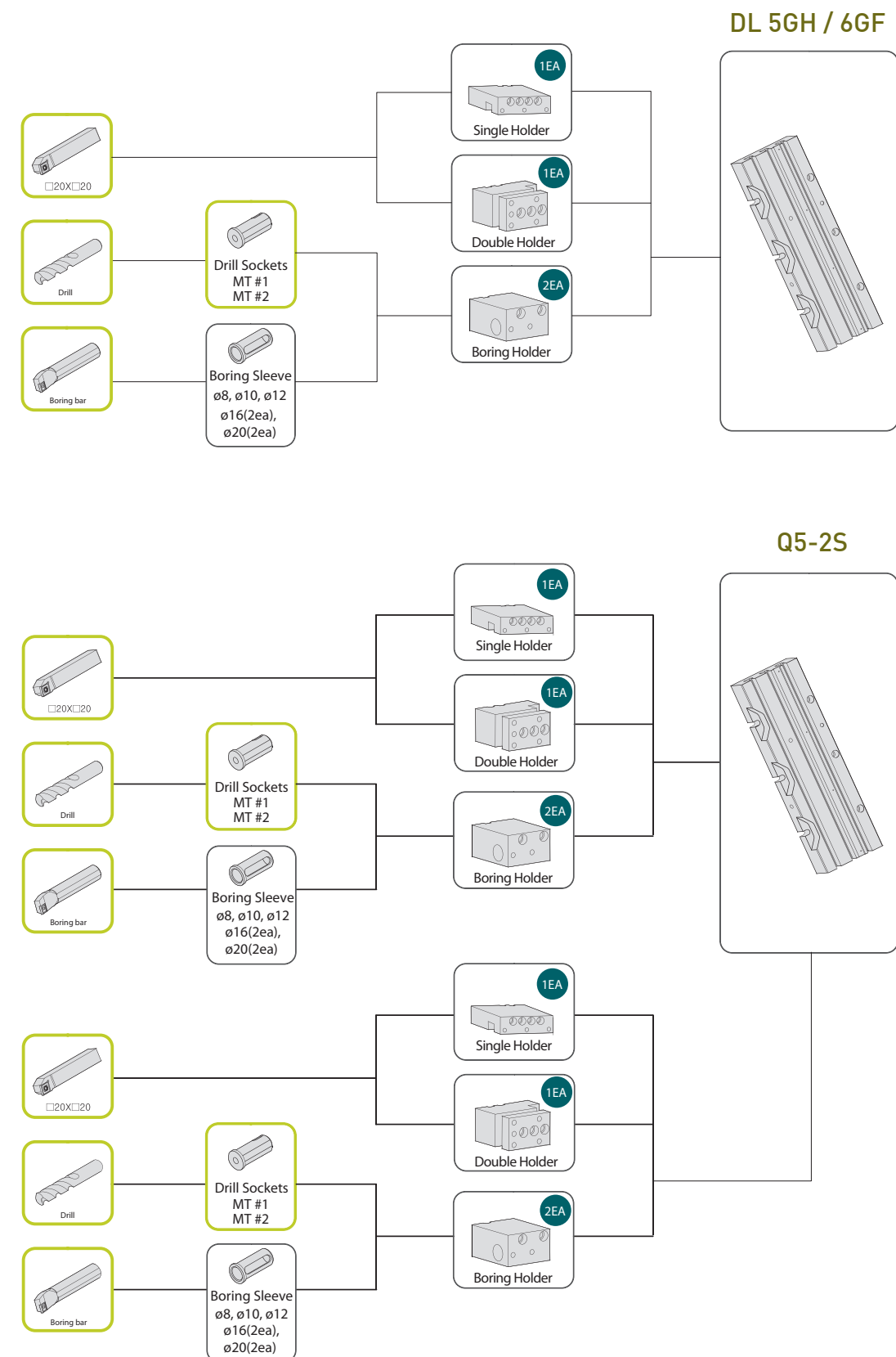



## Working Range

Unit : mm(inch)

### DL 3G

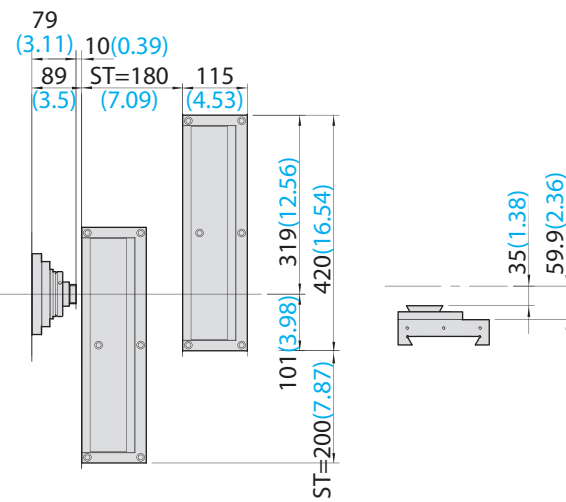

### DL 5GH

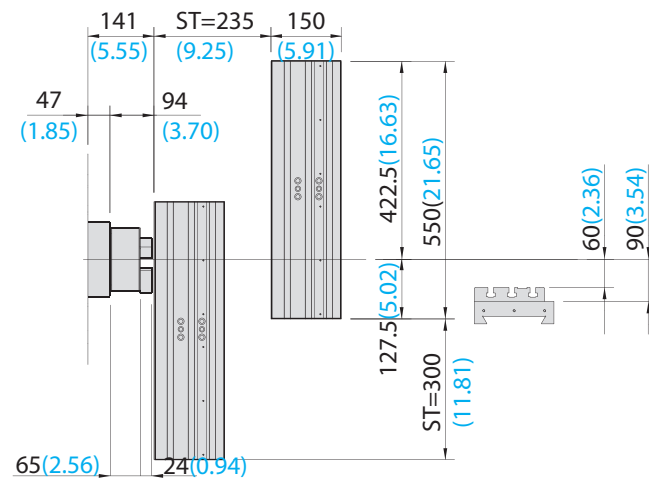

### DL 6GF

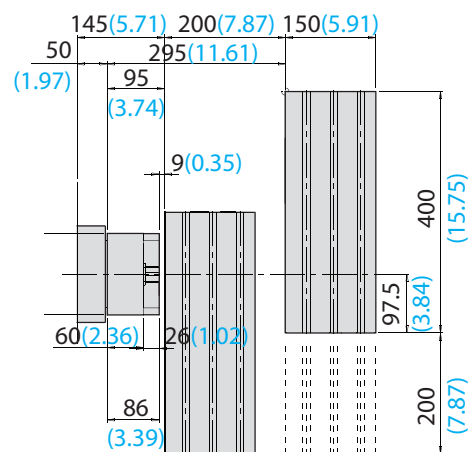

### Q5-2S

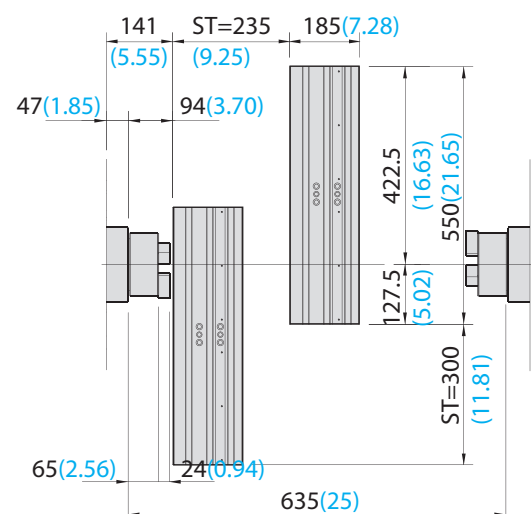

## Machine Lay-Out

Unit : mm(inch)

### DL 3G

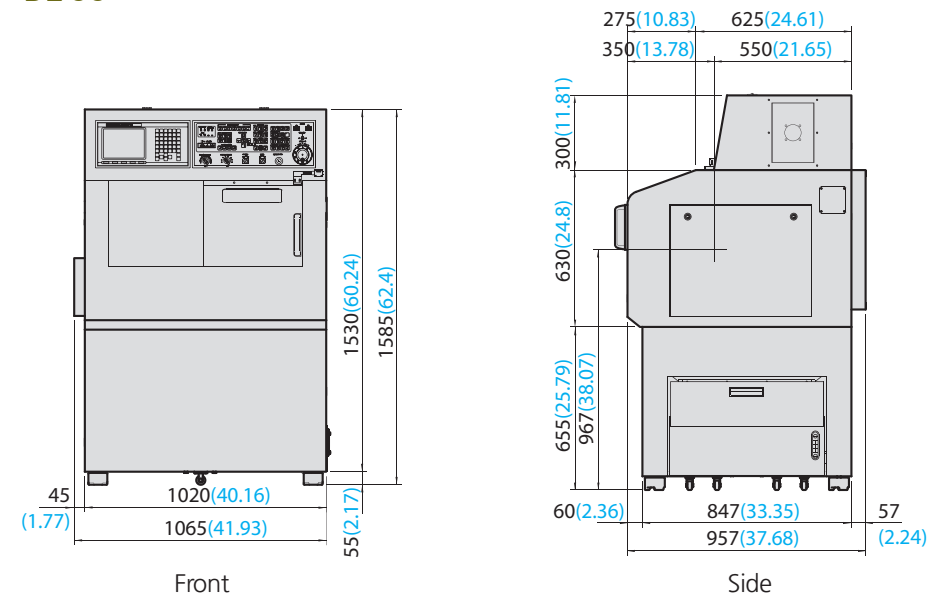

### DL 6GF

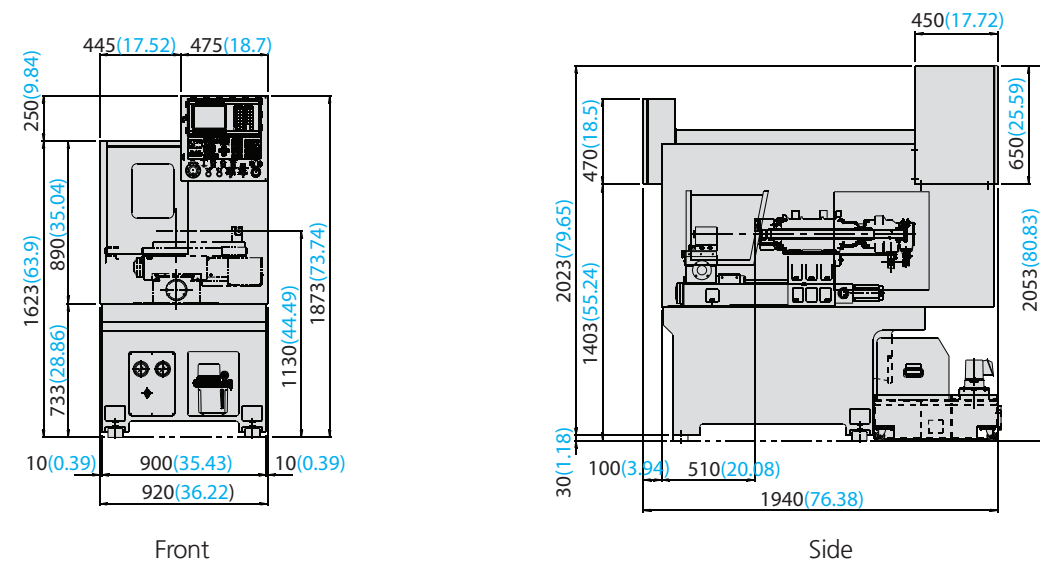

**Machine Lay-Out**

Unit : mm(inch)

**DL 5GH**

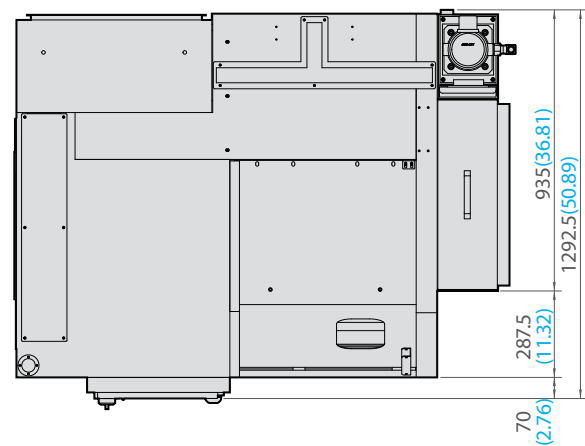

Top

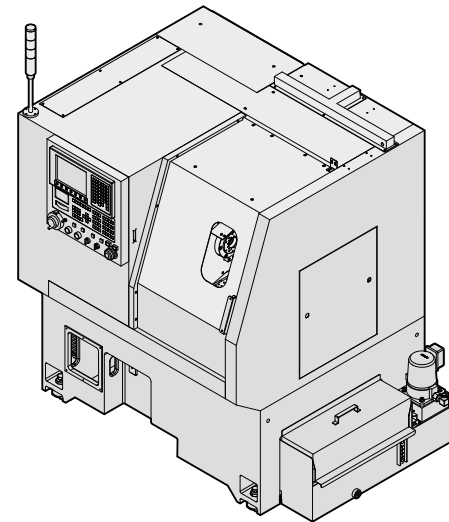

Perspective

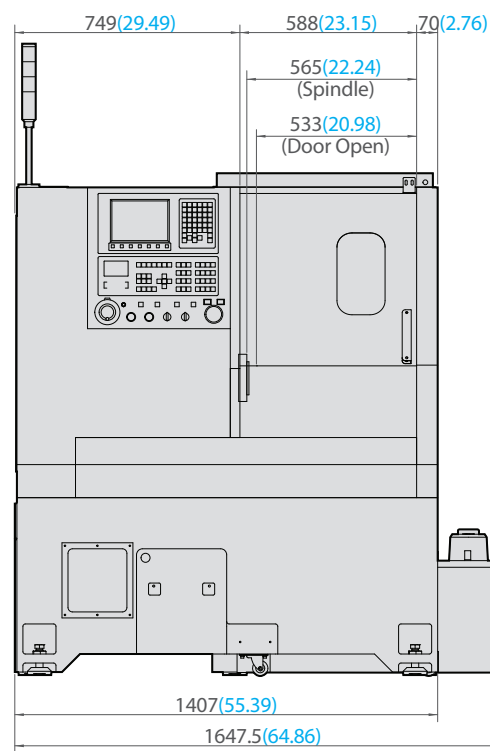

Front

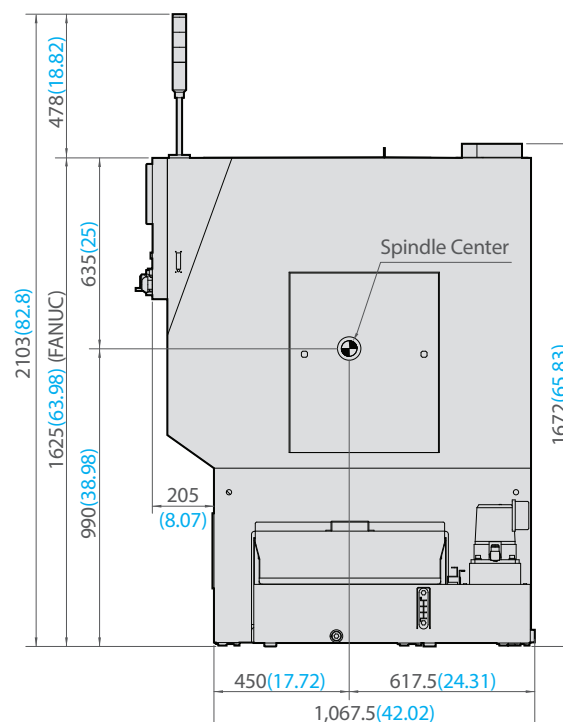

Side

**Machine Lay-Out**

Unit : mm(inch)

**Q5-2S**

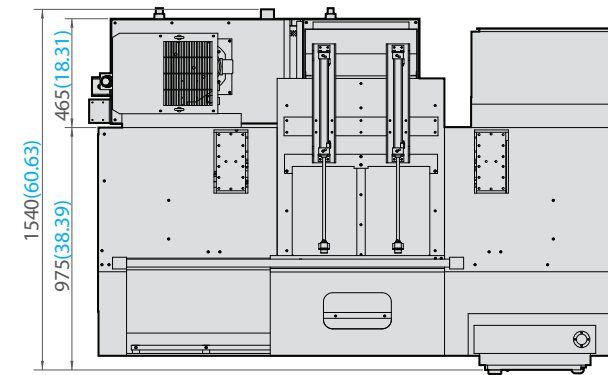

Top

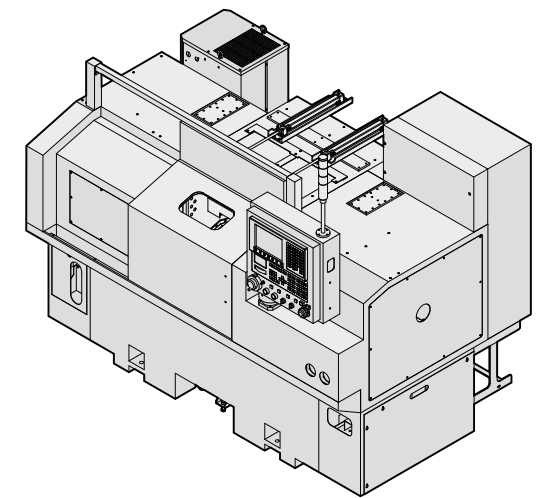

Perspective

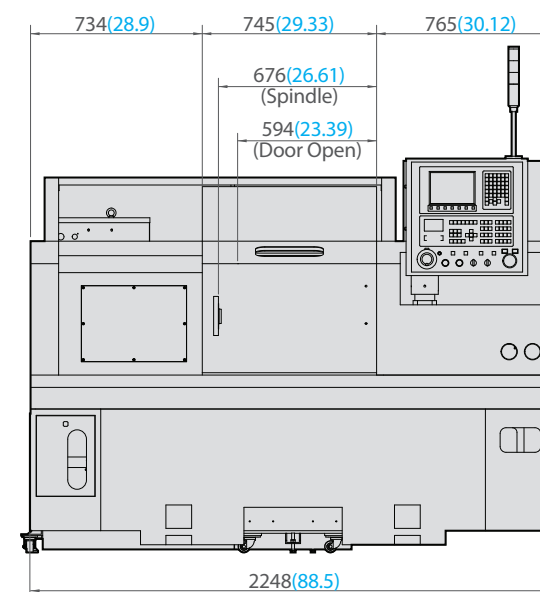

Front

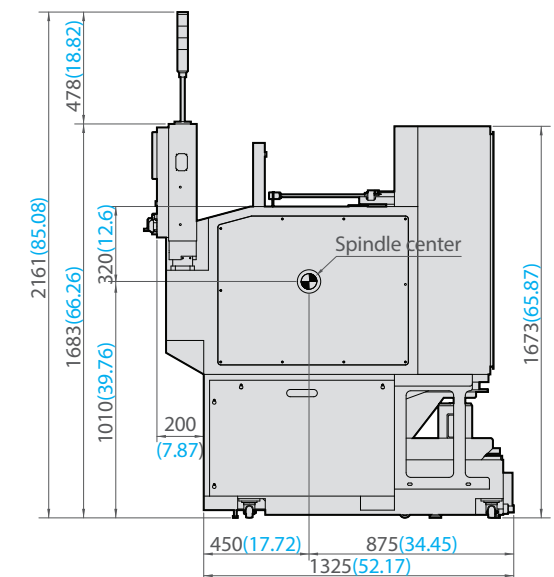

Side



### Machine Specifications

( ) : Option

Specifications				DL 3G		DL 5GH		
Capacity	Swing over Bed (Max. swing dia.)	mm	inch	230	9.06	360	14.17	
	Swing over Cross slide	mm	inch	70	2.76	110	4.33	
	Max. Turning Length	mm	inch	150	5.91	150	5.91	
	Max. Turning Dia.	mm	inch	70	2.76	110	4.33	
Main spindle	Max. Spindle Speed	rpm		6,000		6,000		
	Spindle Nose	-		FLAT		FLAT		
	Spindle Bore diameter	mm	inch	32	1.26	44	1.73	
	Max. Spindle Torque	kgf-m	lbs-ft	3.5	25.32	3.5	25.32	
	Spindle Driven Method	-		Belt		Belt		
	Standard Chuck Size	inch		3/Collet		5		
Motor	Main Spindle Motor(Cont./30min)	kw	hp	3.7/5.5	5/7.4	3.7/5.5	5/7.4	
	X axis Servo Motor	kw	hp	0.75	1.01	0.75	1.01	
	Z axis Servo Motor	kw	hp	0.75	1.01	0.75	1.01	
Travel	X axis travel	mm	inch	200	7.87	300	11.81	
	Z axis travel	mm	inch	180	7.09	235	9.25	
	Guideway Type(X/Z)	-		Dove-tail		Dove-tail		
	X axis rapid traverse rate	m/min	ipm	15	590.55	24	944.88	
	Z axis rapid traverse rate	m/min	ipm	15	590.55	24	944.88	
Turret	Turret Index Type	-		Gang		Gang		
	Max. No. of Tools	ea		5		5		
	Turning tool shank size	mm	inch	12	0.47	20	0.79	
	Boring bar diameter	mm	inch	20	0.79	25	0.98	
General	Machine Weight	kgf	lbs	800	1,764	1,700	3,748	
	Machine height	mm	inch	1,585	62.40	1,670	65.75	
	Floor space	Length	mm	inch	1,250	49.21	1,650	64.96
		Width	mm	inch	960	37.80	1,210	47.64
	Power capacity	kVA		8		9		
	Controller			FOi-TF		FOi-TF		

### Machine Specifications

( ) : Option

Specifications				DL 6GF		Q5-2S		
Capacity	Swing over Bed (Max. swing dia.)	mm	inch	360	14.17	360	14.17	
	Swing over Cross slide	mm	inch	110	4.33	115	4.53	
	Max. Turning Length	mm	inch	150	5.91	250	9.84	
	Max. Turning Dia.	mm	inch	110	4.33	115	4.53	
Main spindle	Max. Spindle Speed	rpm		6,000		6,000		
	Spindle Nose	-		A2-5		A2-4		
	Spindle Bore diameter	mm	inch	55	2.17	26	1.02	
	Max. Spindle Torque	kgf-m	lbs-ft	3.65	26.40	2.4	17	
	Spindle Driven Method	-		Belt		Built-in Motor		
	Standard Chuck Size	inch		6		5		
Motor	Main Spindle Motor(Cont./30min)	kw	hp	7.5/11	10/14.7	<2.2/3.7>x2	<3/5>x2	
	X axis Servo Motor	kw	hp	0.75	1.01	1	1.34	
	Z axis Servo Motor	kw	hp	0.75	1.01	1	1.34	
Travel	X axis travel	mm	inch	200	7.87	300	11.81	
	Z axis travel	mm	inch	200	7.87	235	9.25	
	Guideway Type(X/Z)	-		Dove-tail		Dove-tail		
	X axis rapid traverse rate	m/min	ipm	24	944.88	24	944.88	
	Z axis rapid traverse rate	m/min	ipm	24	944.88	24	944.88	
Turret	Turret Index Type	-		Gang		Gang		
	Max. No. of Tools	ea		3		5		
	Turning tool shank size	mm	inch	20	0.79	20	0.79	
	Boring bar diameter	mm	inch	25	0.98	25	0.98	
General	Machine Weight	kgf	lbs	1,800	3,968	2,300	5,071	
	Machine height	mm	inch	2,050	80.71	1,690	66.54	
	Floor space	Length	mm	inch	950	37.40	2,250	88.58
		Width	mm	inch	1,940	76.38	1,540	60.63
	Power capacity	kVA		19		11		
	Controller			FOi-TF		FOi-TF		

### NC Specifications (FANUC F0i-TF3)

○ : Standard, OPT. : Option, (!) : M type, (!!) : 250 type

	Item	Specification	0iTF3
Controls	Controlled axes	Std. 2axes	X, Z
	Simultaneously control axes expansion(Total)	0.001mm/0.0001"	2 axes
Axis Functions	Least input increment		○
	HRV2 control		○
	Inch/metric conversion	G20/G21	○
	Increment system 1/10	0.0001mm/0.00001"	○
	Stored stroke 1	Overtravel control	○
	Stored stroke 2 and 3		○
	Mirror image		○
	Chamfering on/off		○
	Backlash compensation	Max. 255 pulses	○
	Stored pitch error compensation		○
	Operation	Automatic operation(memory)	
MDI operation			○
Buffer register			○
Program restart			○
Search function		Sequence NO. / Program NO. / Address	○
DNC operation			○
Reference position shift			-
Manual handle feed rate		X1, X10, X100	○
Manual pulse generator		1unit	○
Manual handle interruption			○
Interpolation	Linear interpolation	G01	○
	Circular interpolation	G02, G03	○
	Dwell	G04	○
	Thread cutting/Synchronous cutting		○
	Multiple threading		○
	Thread cutting retract		○
	1st, 2nd reference position return & check	G27, G28, G30	○
	Variable lead thread cutting		○
	Continuous thread cutting		○
	Circular thread cutting		OPT.
3rd and 4th reference point return		○	
polygon turning		OPT.	
Helical interpolation		OPT.	
Feed functions	Rapid traverse override	F0/25/50/100%	○
	Feedrate Override	0-200% (10% unit)	○
	Jog feed override	0-2000 mm/min	○
	Feed per minute	G98	○
	Feed per revolution	G99	○
	Cutting feedrate clamp		○
	External deceleration		○
	Feed stop		-
	Advanced preview control		OPT.
Auxiliary & Spindle functions	Spindle speed override	0~150%	○
	Constant surface speed control	G96, G97	○
	1st Spindle orientation		○
	Rigid tapping		○
	Auxiliary function	M8 digit	○
Programming functions	Program/code	EIA/ISO	○
	Optional block skip	1 Piece	○
	Additional block skip	Total 0(Only NC function)	○

	Item	Specification	0iTF3
Programming functions	Maximum command dimension	± 99999.999mm/(± 9999.9999 inch)	○
	Program file name	32 characters	○
	Sequence number	N8 digit	○
	Absolute / Incremental programming		○
	Decimal point input		○
	Work coordinate system selection	G52 ~ G59	○
	Direct drawing dimension programming		○
	G code system A		○
	G code system B/C(selectable)		○
	Chamfering / corner R		○
	Programmable data input	G10	○
	Sub program call	Nested holds	10
	Custom macro B		○
	Simple canned cycle	G90, G92, G94	○
	Circular interpolation by R programming		○
	Multi repetitive canned cycle	G70 ~ G76	○
	Multi repetitive canned cycle2		○
	Drilling canned cycle(G80 series)		○
	Tape format for FANUC series 15		-
	Tape format for FANUC series 10/11		○
Manual guide oi		OPT.	
Tool functions	Tool number command(t-code function)	T4-digit	○
	Number of tool offsets		128 Pairs
	Tool offset	G43, G44, G49	○
	Tool nose radius compensation	G40 ~ G42	○
	Tool geometry / wear offset	Geometry & wear data	○
	Tool life management		○
	Tool offset value counter input		○
	Auto tool offset		○
Direct input of tool offset value measured B		○	
Editing op. functions	Part program storage size		512 kb
	No. of Registered programs		400 ea
	Part program editing		○
	Program protect		○
	Background editing		○
Expanded part program editing	Copy, Move, Change of NC program		○
Setting & display	Status display		○
	Program name display	31 characters	○
	Self diagnostic function		○
	Help function	Alarm & Operation display	○
	Running tiome / Parts number display	Auto running time & Parts No. display	○
	Load meter display	Spindle & Servo load display	○
	External message display		○
	Display of spindle speed and T-code at all screen		○
	Tool path graphic display		○
	Servo setting screen		○
Spindle setting screen		○	
Multi language display		○	
Data input & output	Reader puncher control	CH1 interface	○
	I/O interface	RS-232C	○
	Memory card input and output		○
	External key input		○
	External program input		○
	External work number search		○
	USB Memory	Input/Output	○
Data Server	Only 1 path, need option board	-	
Other functions	MDI / DISPLAY unit		8.4"
	PMC system		○
	Ethernet function	Embedded ethernet function	○