

UR1000

五軸加工中心機 5-Axis Machining Center

匠澤

With a motorized 1-axis Italy swivel head spindle on a robust double column frame (could be have an option for 2-axis swivel head), the highly flexible UR1000 is available with:

- 1000 mm C-axis rotary
- Dual tables including 1000 mm C-axis rotary and 1600 x 1000 mm flat rectangular
- 1600 x 2000 mm flat rectangular (could be configured with A-axis rotary and power tail support)



機械規格 Specifications

		單位 Unit	UR1000
行程	Travel		
X 軸	X axis	mm	1500
Y 軸	Y axis	mm	2040
Z 軸	Z axis	mm	1000
主軸鼻端到工作台距離	Distance from spindle nose to table	mm	810
工作台	Table		
工作台面積	Dimension	mm	Ø1000
工件最大高度	Workpiece Max. height	mm	700
工作台最大荷重	Max. load	kg	2500
T型槽(寬度 x 數量)	T-slot (width x number)	mm	22x8
主軸	Spindle		
主軸型式	Spindle type	-	內藏 Built-in
主軸轉速	Spindle speed	rpm	24000
主軸馬達功率(cont. / S6-40%)	Motor power (cont. / S6-40%)	kW	42/55
主軸最大扭力(cont. / S6-40%)	Spindle Max. torque (cont. / S6-40%)	Nm	67/87.5
主軸錐度	Spindle taper	-	HSK A63
進給	Feed		
快速進給速率(X/Y/Z)	Rapid traverse(X/Y/Z)	m/min	20/16/20
切削進給速率	Cutting feed rate	mm/min	12000
旋轉主軸	Swivelling spindle heads		
A軸 旋轉範圍	A axis rotation range	degree	±110°
A軸 定位精度	A axis positioning accuracy	"	8
A軸 旋轉速度	A axis rotation speed	rpm	180
A軸 旋轉扭矩(連續)	A axis rotation torque (cont.)	Nm	782
A軸 旋轉扭矩(最大)	A axis rotation torque(max.)	Nm	1414
A軸 夾持扭矩	A axis clamping torque	Nm	4000
C軸 旋轉範圍	C axis rotation range	degree	360
C軸 定位精度	C axis positioning accuracy	"	±2
C軸 旋轉速度	C axis rotation speed	rpm	90
C軸 旋轉扭矩(連續)	C axis rotation torque (cont.)	Nm	1230
C軸 旋轉扭矩(最大)	C axis rotation torque (max.)	Nm	2800
C軸 夾持扭矩	C axis clamping torque	Nm	4000
ATC & 刀庫	ATC & magazine		
刀庫型式	ATC type	-	鏈條式 Chain type
刀庫容量	Magazine capacity	pcs	40
最大刀徑:相鄰刀/空鄰刀	Max. tool diameter (next pockets empty)	mm	Ø75 / Ø100
最大刀具長度	Max. tool length	mm	400
最大刀具重量	Max. tool weight	kg	7
空間&系統需求	Space& System Requirement		
氣壓源	Pneumatic pressure	kgf/cm ²	6
電力源	Electrical power consumption	kVA	80
機器淨重	Machine net weight	kg	28000
最大占地面積(W x L x H)	Max. floor space (W x L x H)	mm	4590x4625x4865

UR1000

五軸加工中心機 5-Axis Machining Center

主要機械外觀尺寸 Dimensions (單位 Unit: mm)

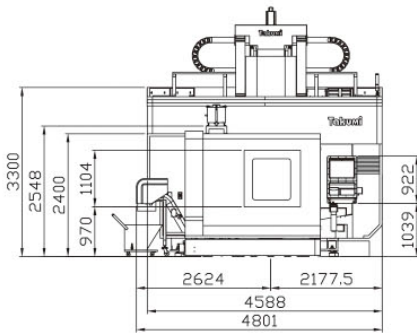

側視圖 Side View

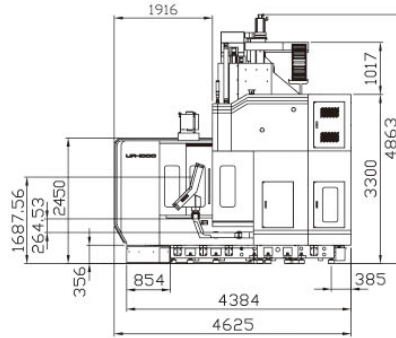

正視圖 Front View

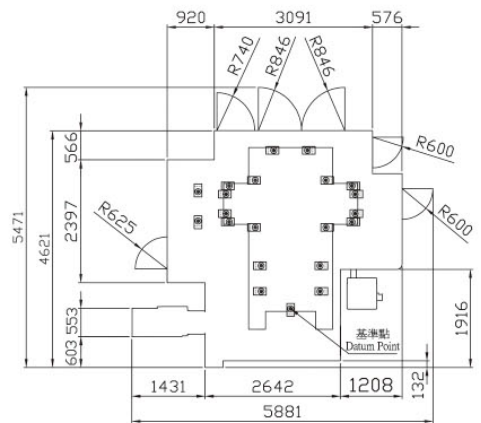

上蓋圖 Top View

■ 標準配件

- ◆ HEIDENHAIN TNC640 控制器
- ◆ 24000rpm, HSK A63, 內藏式主軸 (義大利HSD)
- ◆ 40刀, 刀臂式刀庫
- ◆ 油水分離裝置
- ◆ 自動刀長量測
- ◆ 主軸冷卻系統
- ◆ A&C軸冷卻系統
- ◆ 切削冷卻液系統
- ◆ 自動集中潤滑系統
- ◆ 主軸吹氣裝置
- ◆ 切削吹氣
- ◆ 三色警示燈
- ◆ 工作照明燈
- ◆ 清潔水槍&氣槍
- ◆ 標準水箱
- ◆ 鏈板式鐵屑輸送機
- ◆ 電氣箱空調冷卻機
- ◆ 三軸光學尺
- ◆ MPG手搖輪
- ◆ 網路RS-232介面
- ◆ 基本工具箱
- ◆ 全密閉式防護罩
- ◆ 操作手冊
- ◆ 水平調整螺栓及基礎墊塊
- ◆ 一年機器保固
- ◆ 控制器保固
- ◆ CE安全規範

■ Standard Accessories

- ◆ HEIDENHAIN TNC640 controller
- ◆ 24000 rpm, HSK A63, Built-in type spindle (HSD, Italy)
- ◆ 40T, Arm type ATC
- ◆ Oil skimmer
- ◆ Automatic tool length measurement system
- ◆ Spindle cooling system
- ◆ A&C axis cooling system
- ◆ Cutting coolant system
- ◆ Centralized auto lubrication system
- ◆ Spindle air blast
- ◆ Cutting air blast
- ◆ 3-color signal lamp
- ◆ Working lamp
- ◆ Washing gun& air gun
- ◆ Coolant tank
- ◆ Steel belt chip conveyor
- ◆ Air conditioner for electrical cabinet
- ◆ Linear scales
- ◆ Manual pulse generator
- ◆ Ethernet card & RS-232C interface
- ◆ Tool kits
- ◆ Fully enclosed splash guard
- ◆ Operation manuals, PLC, electrical circuit drawings
- ◆ Anchor bolts, pads set leveling blocks and bolts
- ◆ One year machine warranty
- ◆ Controller warranty
- ◆ CE

■ 選擇配備

- ◆ 主軸中心出水 (30BAR or 70BAR)
- ◆ 50刀, 刀臂式刀庫
- ◆ 三軸螺桿中空冷卻
- ◆ 切削油霧裝置
- ◆ 油霧回收裝置
- ◆ 工件量測
- ◆ 變壓器
- ◆ Kinematic Opt with TS740 + Calibration sphere, Software option 2

■ Optional Accessories

- ◆ Coolant through spindle (30BAR or 70BAR)
- ◆ 50T, Arm type ATC
- ◆ Ball screw oil cooling system
- ◆ Cutting oil mist device
- ◆ Oil mist collector device
- ◆ Workpiece measurement system
- ◆ Transformer
- ◆ Kinematic Opt with TS740 + Calibration sphere, Software option 2

Takumi 匠澤

437台中市大甲區工十路10號
No.10, Gong 10th Rd., Dajia Dist., Taichung City 437, Taiwan
Tel: 886-4-26811215 Fax: 886-4-26822803
Website: <http://www.takumi.com.tw>
E-mail: sale-os@takumi.com.tw

